



ENTRE//MATIC

CE

CROSS5-7-8

IP1747EN - rev. 2010-08-23



EN

**Installation and
maintenance manual for
sliding gates.**

(Original instructions)



ISO 9001
Cert. n° 0957

DITEC S.p.A.

Via Mons. Banfi, 3 - 21042 Caronno Pertusella (VA) - ITALY

Tel. +39 02 963911 - Fax +39 02 9650314

www.ditec.it - ditec@ditecva.com

INDEX

Subject	Page
1. General safety precautions	3
2. Declaration of incorporation of partly completed machinery	4
2.1 Machinery directive	4
3. Technical data	5
3.1 Applications	5
4. Standard installation	6
4.1 References and accessories	7
5. Installation	8
5.1 Preliminary checks	8
5.2 Base plate position	8
5.3 Geared motor installation	10
5.4 Rack installation	10
5.5 Limit switch adjustment	11
5.6 Operation by encoder	11
5.7 CROSS7EHTC installation	12
5.8 Chain installation	12
6. Electrical connections	13
7. CROSS7SF photocells installation	13
8. LUXK7 installation	14
9. BATK7 installation	15
10. Ordinary maintenance program	15
11. User instructions	16
11.1 General safety precautions	16
11.2 Manual release instruction	17

All rights reserved

All data and specifications have been drawn up and checked with the greatest care. The manufacturer cannot however take any responsibility for eventual errors, omissions or incomplete data due to technical or illustrative purposes.

1. GENERAL SAFETY PRECAUTIONS



This installation manual is intended for professionally competent personnel only.

Installation, electrical connections and adjustments must be performed in accordance with Good Working Methods and in compliance with applicable regulations.

Before installing the product, carefully read the instructions.

Bad installation could be hazardous.

The packaging materials (plastic, polystyrene, etc.) should not be discarded in the environment or left within reach of children, as these are a potential source of hazard.

Before installing the product, make sure it is in perfect condition.

Do not install the product in an explosive environment and atmosphere: gas or inflammable fumes are a serious hazard risk.

Before installing the motors, make all structural changes relating to safety clearances and protection or segregation of all areas where there is risk of being crushed, cut or dragged, and danger areas in general.

Make sure the existing structure is up to standard in terms of strength and stability.

The motor manufacturer is not responsible for failure to use Good Working Methods in building the frames to be motorized or for any deformation occurring during use.

The safety devices (photocells, safety edges, emergency stops, etc.) must be installed taking into account: applicable laws and directives, Good Working Methods, installation premises, system operating logic and the forces developed by the motorized gate.

The safety devices must protect any areas where the risk exists of being crushed, cut or dragged, or where there are any other risks generated by the motorized gate.

Apply hazard area notices required by applicable regulations.

Each installation must clearly show the identification details of the motorized gate.



Before making power connections, make sure the plate details correspond to those of the power mains.

Fit an omnipolar disconnection switch with a contact opening gap of at least 3 mm.

Make sure an adequate residual current circuit breaker and overcurrent cutout are fitted upstream of the electrical system.

When necessary, connect the motorized gate to a reliable earth system made in accordance with applicable safety regulations.

During installation, maintenance and repair, interrupt the power supply before opening the lid to access the electrical parts.



To handle electronic parts, wear earthed antistatic conductive bracelets.

The motor manufacturer declines all responsibility in the event of component parts being fitted that are not compatible with the safe and correct operation.

For repairs or replacements of products only original spare parts must be used.

The installer shall provide all information relating to automatic, manual and emergency operation of the motorized gate, and provide the user with operating instructions.

2. DECLARATION OF INCORPORATION OF PARTLY COMPLETED MACHINERY

(Directive 2006/42/EC, Annex II-B)

The manufacturer DITEC S.p.A. with headquarters in Via Mons. Banfi, 3 - 21042 Caronno Pertusella (VA) - ITALY declares that the automation system for CROSS5-7-8 sliding gates:

- has been constructed to be installed on a manual door to construct a machine pursuant to the Directive 2006/42/EC. The manufacturer of the motorized door shall declare conformity pursuant to the Directive 2006/42/EC (annex II-A), prior to the machine being put into service;
- conforms to applicable essential safety requirements indicated in annex I, chapter 1 of the Directive 2006/42/EC;
- conforms to the Low Voltage Directive 2006/95/EC;
- conforms to the Electromagnetic Compatibility Directive 2004/108/EC;
- technical documentation conforms to Annex VII-B to the Directive 2006/42/EC;
- technical documentation is managed by Renato Calza with offices in Via Mons. Banfi, 3 - 21042 Caronno Pertusella (VA) - ITALY;
- a copy of technical documentation will be provided to national competent authorities, following a suitably justified request.

Caronno Pertusella, 19-07-2010

Silvano Angaroni
(Managing Director)

2.1 Machinery Directive

Pursuant to Machinery Directive (2006/42/EC) the installer who motorizes a door or gate has the same obligations as the manufacturer of machinery and as such must:

- prepare the technical file which must contain the documents indicated in Annex V of the Machinery Directive; (The technical file must be kept and placed at the disposal of competent national authorities for at least ten years from the date of manufacture of the motorized door);
- draw up the EC Declaration of Conformity in accordance with Annex II-A of the Machinery Directive and deliver it to the customer;
- affix the EC marking on the motorized door in accordance with point 1.7.3 of Annex I of the Machinery Directive.

3. TECHNICAL DETAILS

	CROSS5EH	CROSS7E	CROSS7EH	CROSS8E
Power supply	230 V~ / 50-60 Hz	230 V~ / 50 Hz	230 V~ / 50-60 Hz	230 V~ / 50 Hz
Absorption	1,2 A	2 A	1,5 A	3 A
Thrust	400 N	700 N	600 N	800 N
Condenser	-	16 µF	-	22 µF
Max run	20 m	20 m	20 m	20 m
Door speed	0,09 - 0,21 m/s	0,18 m/s	0,12 ÷ 0,20 m/s	0,18 m/s
Max door weight	450 kg	600 kg	600 kg	800 kg
Service class	4 - INTENSE	4 - INTENSE	4 - INTENSE	4 - INTENSE
Min number of consecutive cycles	50	30	50	30
Intermittence	S2 = 30 min S3 = 50%	S2 = 20 min S3 = 50%	S2 = 30 min S3 = 50%	S2 = 20 min S3 = 50%
Temperature	-20 °C/+55 °C	-20 °C/+55 °C	-20 °C/+55 °C	-20 °C/+55 °C
Degree of protection	IP24D	IP24D	IP24D	IP24D
Control panel	73RM	E1A	73RG	E1A

3.1 Operating instructions

Service class: 4 (minimum 10÷5 years of working life with 100÷200 cycles per day).

Applications: INTENSE (for apartment block, commercial and healthcare entrances with intense pedestrian use).

- Performance characteristics are to be understood as referring to the recommended weight (approx. 2/3 of maximum permissible weight). When used with the maximum permissible weight a reduction in the above mentioned performance can be expected.
- Service class, running times, and the number of consecutive cycles are to be taken as merely indicative Having been statistically determined under average operating conditions, and are therefore not necessarily applicable to specific conditions of use.
- Each automatic entrance has variable elements such as: friction, balancing and environmental factors, all of which may substantially alter the performance characteristics of the automatic entrance or curtail its working life or parts thereof (including the automatic devices themselves). The installer should adopt suitable safety conditions for each particular installation.

4. STANDARD INSTALLATION

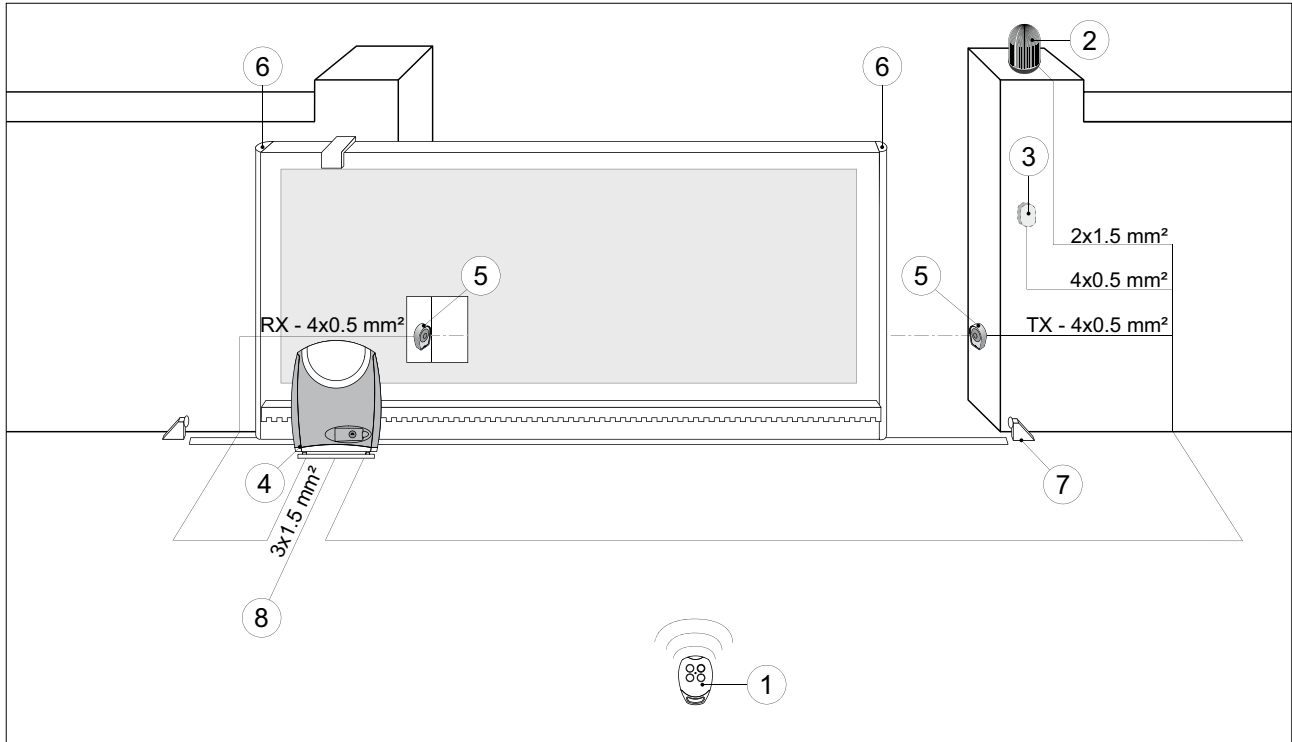

Ref.	Code	Description
1	GOL4	Transmitter
2	LAMP LAMPH	Flashing light
3	XEL5 GOL4M	Key selector Codified via radio control keyboard
4		Geared motor + control panel
5	XEL2 LAB4	Photocells Photocells IP55
6	SOF GOPAV	Rubber edge - Sensitive edge Safety device for sensitive edges
7		Opening and closing mechanical stop
8		Connect the power supply to an approved omnipolar switch with an opening distance of the contacts of at least 3mm (not supplied). The connection to the mains must be made via an independent channel, separated from the connections to command and safety devices.



NOTE: the given operating and performance features can only be guaranteed with the use of DITEC accessories and safety devices.

4.1. References and accessories

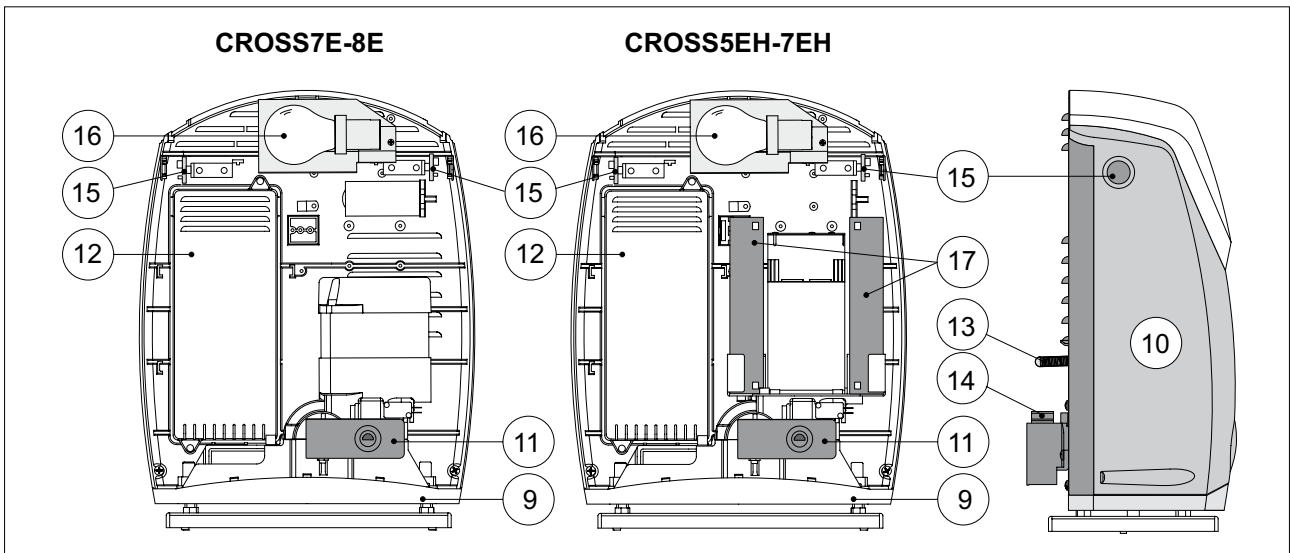
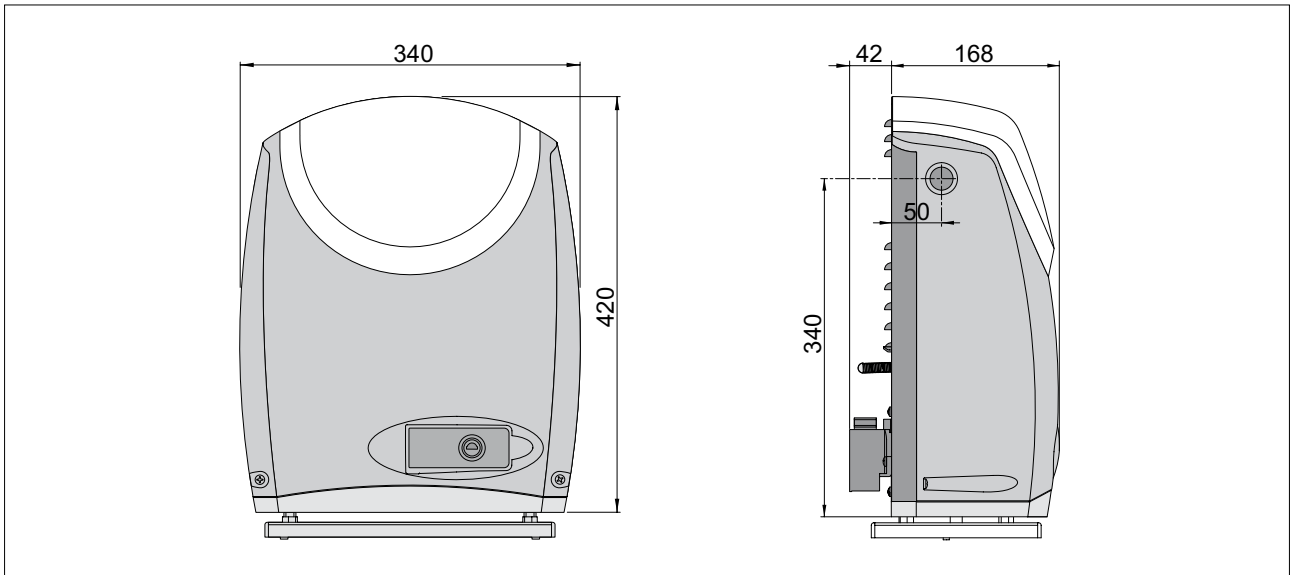

Ref.	Code	Description
9		Motor
10		Casing
11		Release door
12		Control panel
13		Limit-switch spring
14		Pinion
15	CROSS7SF *	Internal photocell
16	LUXK7 *	Courtesy light
17	BATK7 *	Battery kit (Only for CROSS5EH-7EH)

* Optional

5. INSTALLATION

Unless otherwise specified, all measurements are expressed in millimetres (mm).

5.1 Preliminary checks

Check the stability of the wing (derailing and lateral falls) and the sliding wheels and that the upper guides do not cause any friction.

The sliding guide must be securely fixed to the ground for the full length within the doorway and must have no irregularities that could hinder the movement of the gate.

The opening and closing stops must be fitted.

NOTE: make sure that the gate can not exit the sliding guides and fall.

If the gate has slits, make sure they are covered to prevent shearing points.



Safety device should be installed at the end of the wing to reduce the collision force.

5.2 Base plate position

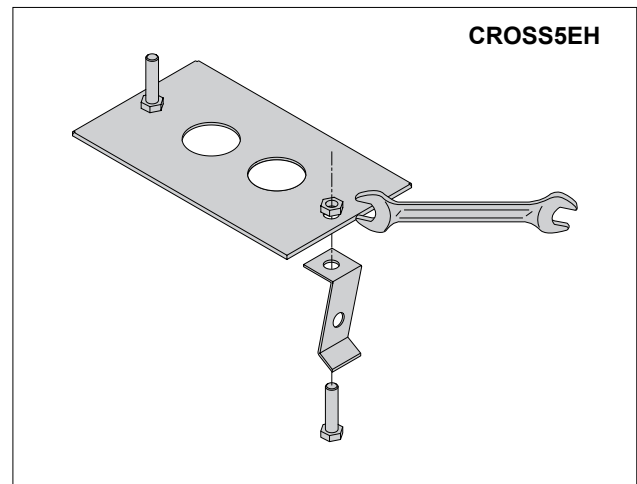
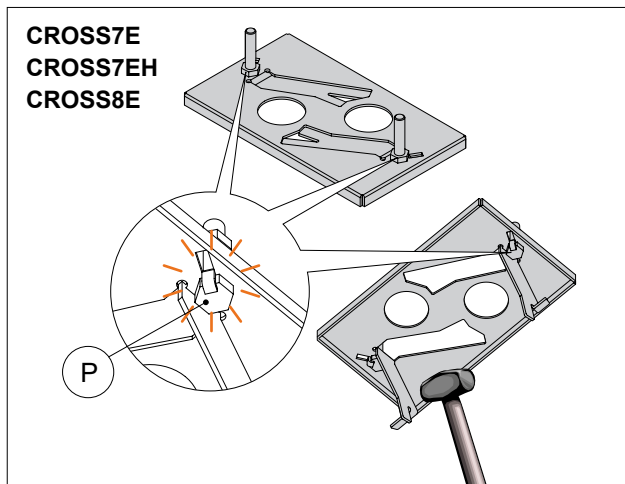
- First, insert the screws into the base plate blocking them with a low nut [P], then, fold the tang to avoid displacement.
- Take out the preformed wall anchors with a downward movement and with the help of a hammer to ensure proper anchorage to the concrete.

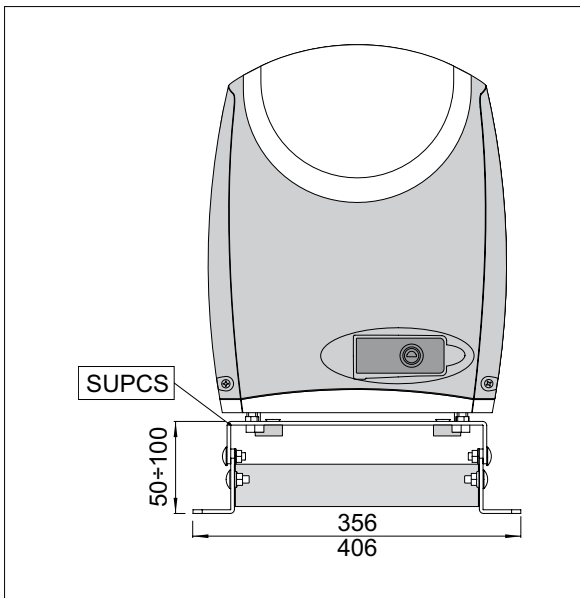

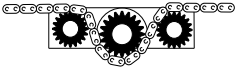

(*) CROSSCRI		X = 40
(*) CROSSCRN2		X = 40
(**) CROSS7EHTC		

- Lay a concrete foundation with buried anchoring brackets and the base plate, making sure that it is perfectly level and smooth, complying with the measurements shown in figure.

NOTE: if the cement area is already present, adjustable SUPCS base can be used.

! WARNING: the gearmotor must be suitably raised from the ground to avoid flooding.

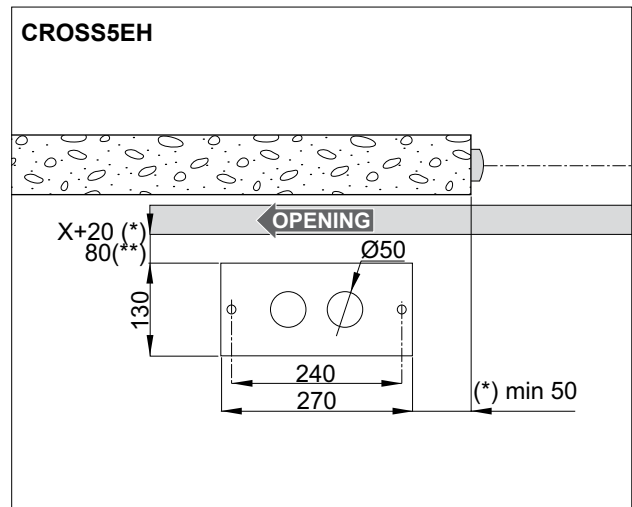
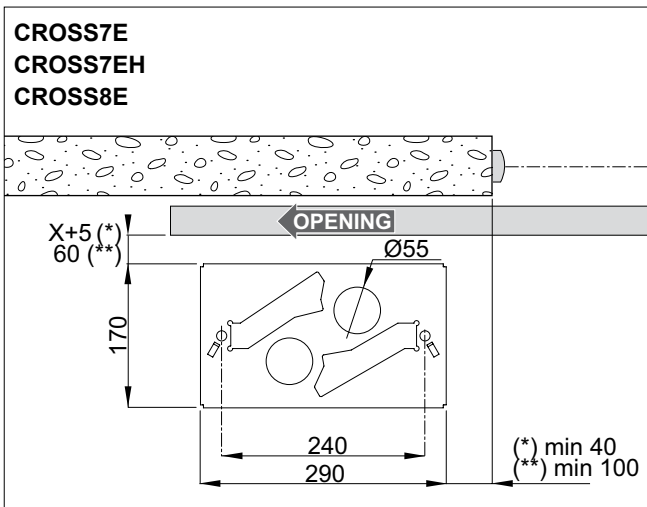

5.3 Geared motor installation

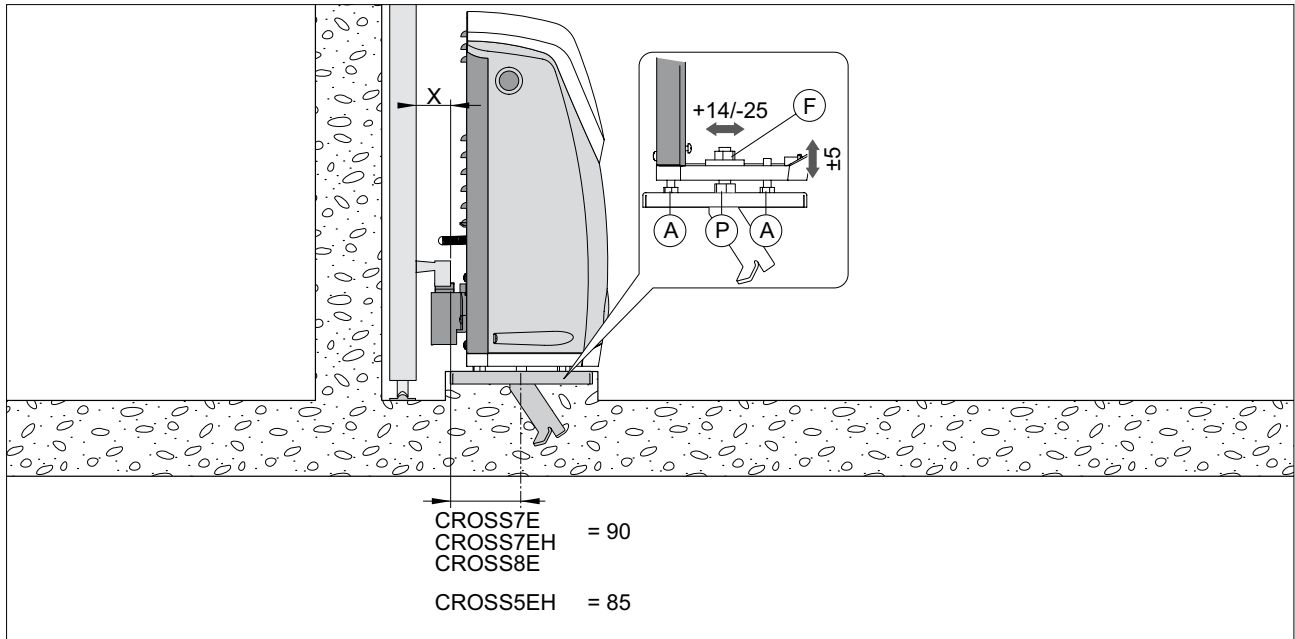

- Release the gearmotor and remove the key. Loosen the three front screws and remove the casing by lifting it slightly.
- Position the gearmotor onto the base plate.
- Gearmotor adjustments
Horizontally slide the gearmotor on the slots of the anchor brackets.
Vertically with the four levelling screws [A].
NOTE: while adjusting vertically, keep the motor slightly raised above the base plate so as to allow enough space to secure the rack and to make any subsequent adjustments, if necessary.

5.4 Rack installation

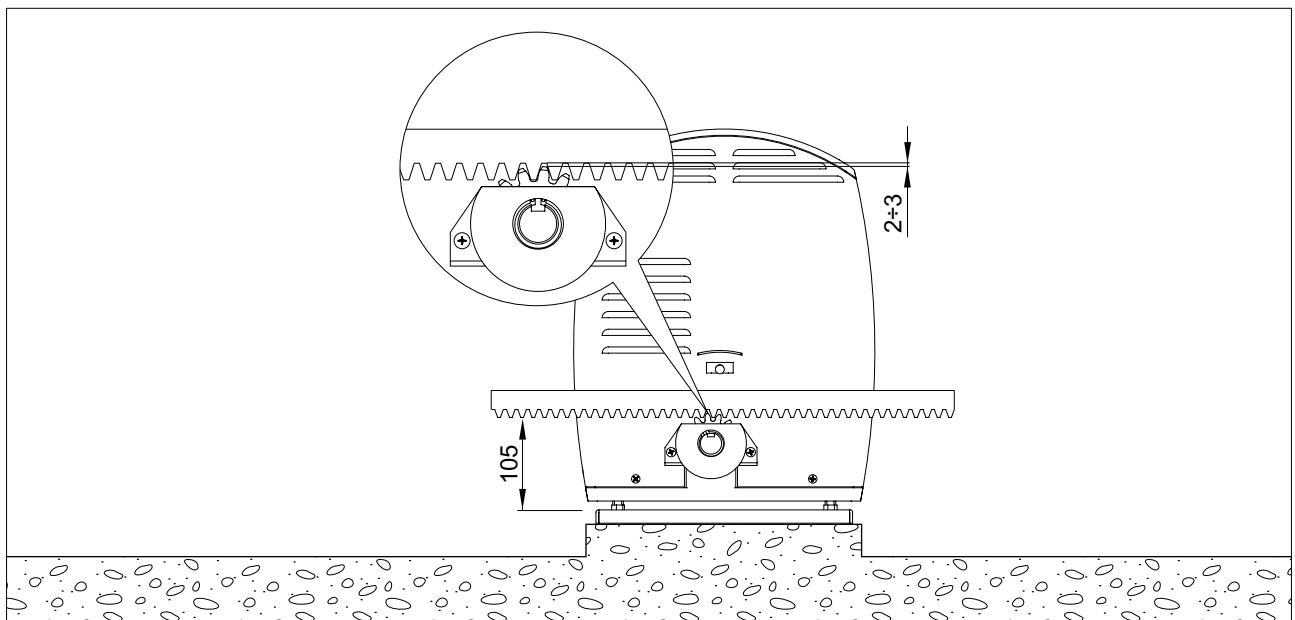

- Release the gearmotor and set the gate in the open position. Place the rack on pinion [14] and move the gate manually to secure the rack along its full length.
- Once the rack has been secured, vertically adjust the geared motor so as to have a gap of 2 to 3 mm between the pinion and the rack with screws [A].
- Firmly secure the gearmotor with the nuts [F].
- Slightly lubricate the rack and pinion after assembly. Manually check that the gate slides evenly and without friction.

5.5 Limit switch adjustment

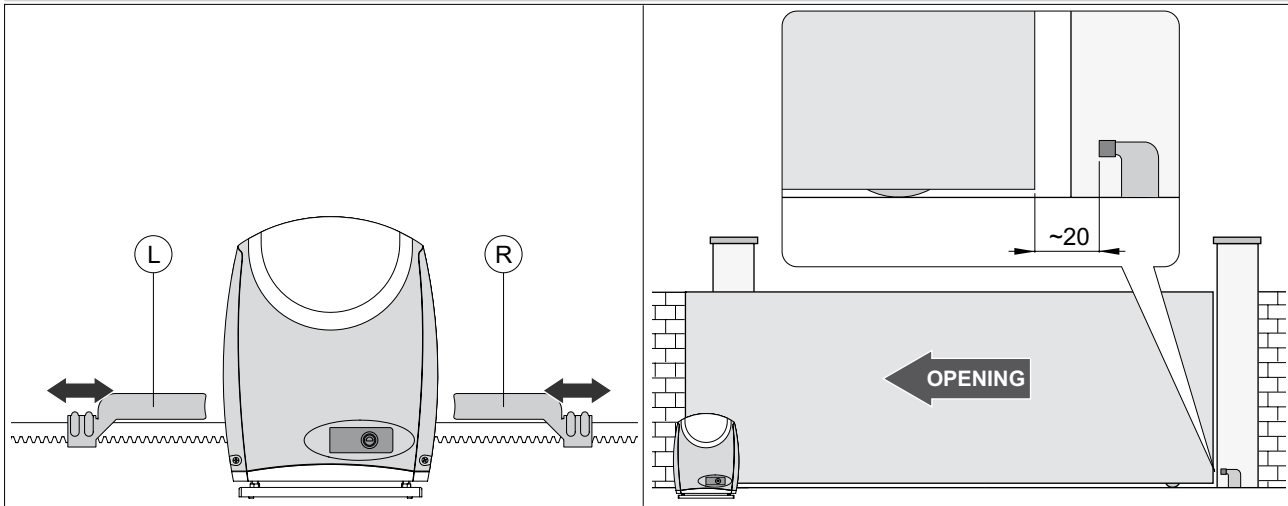

- Manually position the door wing completely open and fasten the limit switch brackets [L] onto the rack so that the lever limit switch exceeds the bracket's length by approximately 2/3. Repeat the operation with door wing completely closed.
- After having performed a certain number of operations, adjust the position of the limit switch bracket [L] so that the gate will stop about 20 mm before the opening and closing stops.

NOTE: (Only for CROSS5EH-7EH) the limit switch kit is optional and it is used to stop the gate before the opening and closing stops. When limit switch is present, slow down is carried out at maximum power to overcome possible friction.

5.6 Operation by encoder

The CROSS5EH-7EH does not require limit switches because it has an encoder. Mechanical stops must necessarily be installed. The gate decelerates automatically in proximity of the mechanical stops.

WARNING: upon reaching the opening or closing limit stop, the gate performs a brief disengaging maneuver (moving reversal) to facilitate the manual release of the geared motor.

5.7 CROSS7EHTC installation (only CROSS5EH-7EH)

Release the gearmotor (see OPERATING INSTRUCTIONS). Remove the pinion [14]. Fix the pinion supporting plate to the gearmotor. Insert the pinion as illustrated in the diagram. Manually pass the chain between the pinions. Fix the cover plate.

WARNING: fitting the chain the drive direction of the gearmotor is inverted.

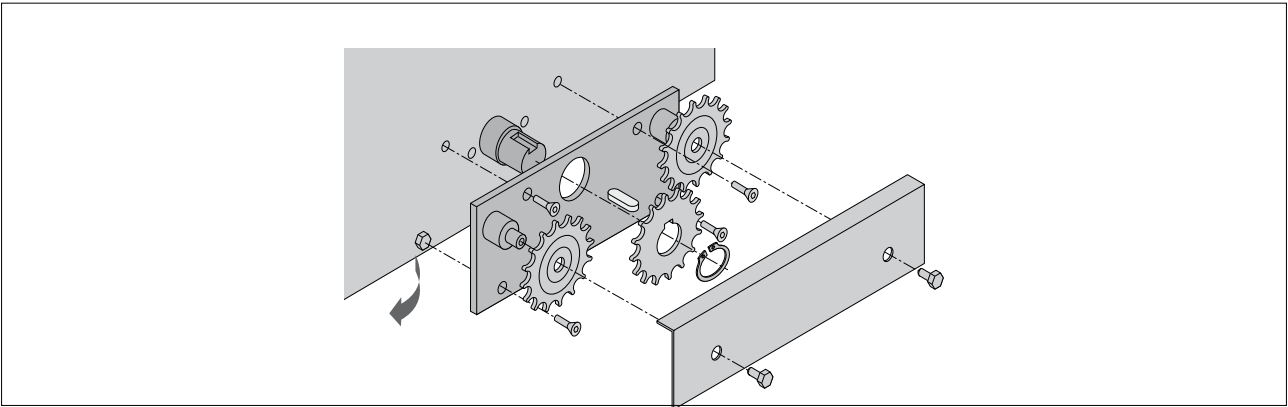

5.8 Chain installation

- Move the gate into the open position and fix brackets [G] onto the gate as illustrated in the figure.

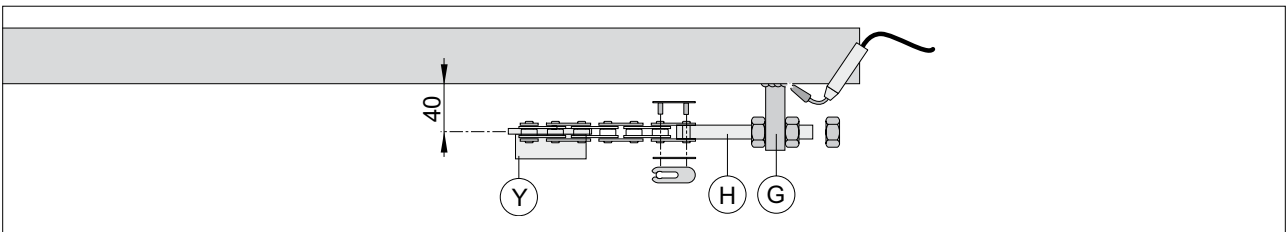

- Connect the chain, which was previously assembled on the gearmotor, to tie rod [H] and fix it to bracket [G].
- Fix bracket [G] on the opposite side of the gate. Connect the chain to the tie rod [H] and fix it to bracket [G] (cut the excess chain).

NOTE: make sure that the distance between the pinion centre [Y] and tie rod [H] is correct when the gate is fully open and closed.

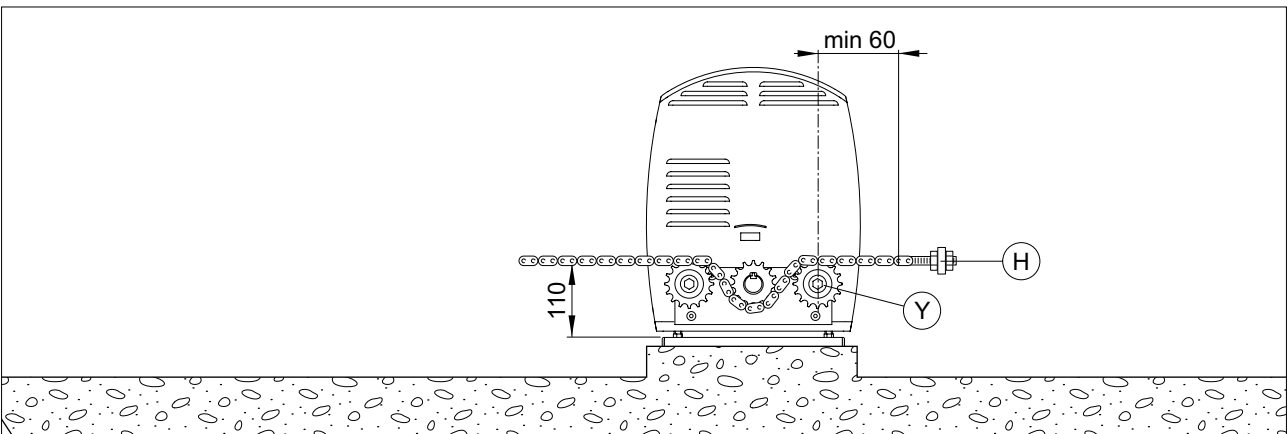

- Secure the gearmotor with the nuts [F].
- Tighten the chain with the tie rod [H].
- Slightly lubricate the chain and pinion after assembly.

6. ELECTRICAL CONNECTIONS

Before connecting the power supply, make sure the plate data correspond to that of the mains power supply. An omnipolar disconnection switch with minimum contact gaps of 3 mm must be included in the mains supply. Check that upstream of the electrical installation there is an adequate residual current circuit breaker and a suitable overcurrent cutout.

The electrical connections and starting are illustrated in the installation manual of the control panel. 230 V~ cables (power supply, flashing light and external courtesy light) are to be positioned on the right of the electric control panel.

24 V= cables (safeties, controls and external antenna) are to be positioned on the left of the electric control panel.

WARNING: Connect the yellow-green ground cable to the clamp already connected to the motor, as it is shown in the figure.

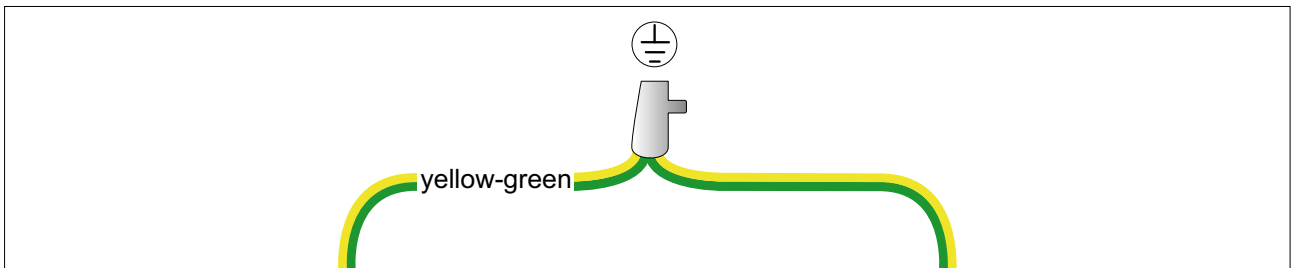

7. CROSS7SF PHOTOCELLS INSTALLATION

Additional photocells may be installed inside the gearmotor for the protection of both opening and closing movement.

Fit a receiver (RX) or a transmitter (TX) on the [U] brackets provided.

Installation of the photocells must be carried out in observance of the standards EN12453 and EN12445.

WARNING: the photocell receiver (RX) and transmitter (TX) may also be installed at two different heights, the maximum permissible difference in height being 300 mm.

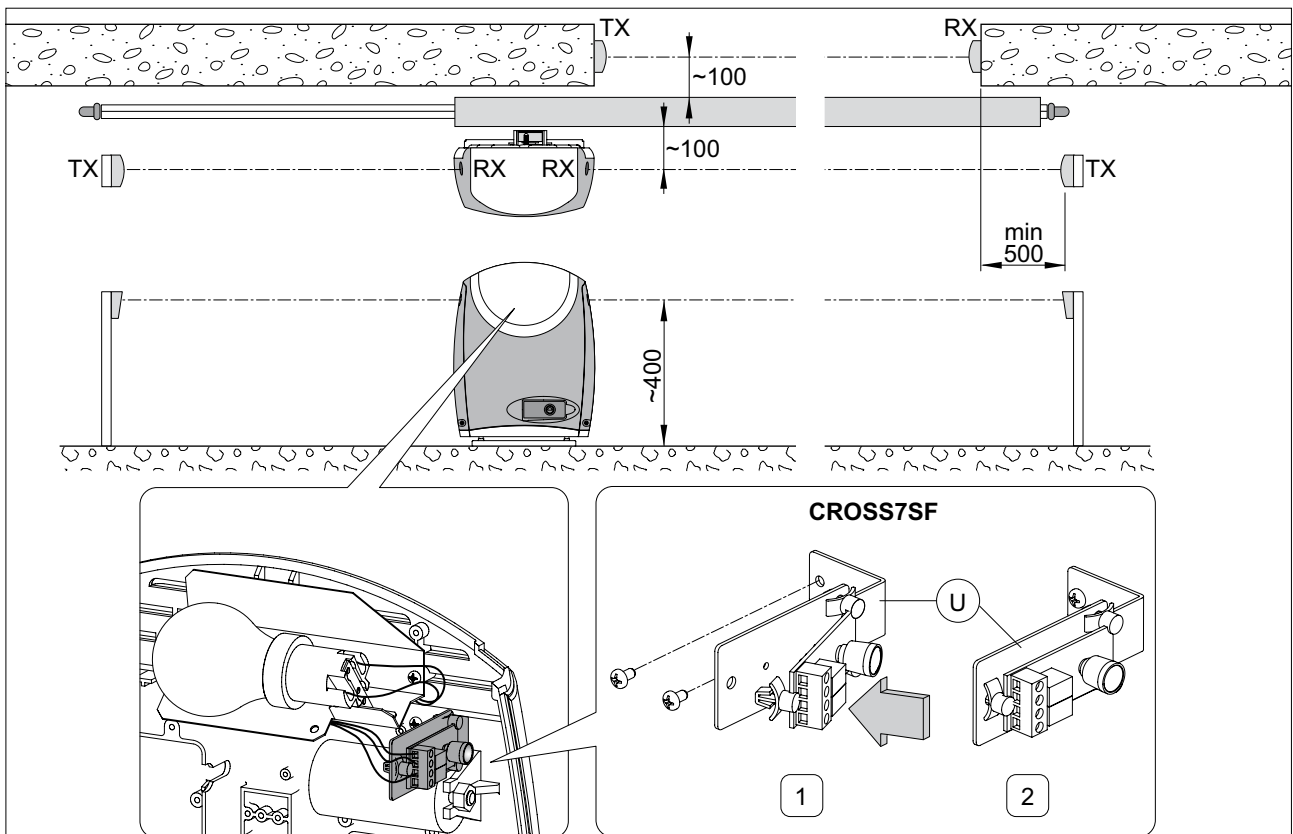

8. LUXK7 INSTALLATION

The courtesy lamp can be mounted inside the gear motor. For mounting and connection, carry out the operations shown in the figure.

WARNING: Connect the yellow-green ground cable to the clamp already connected to the motor, as it is shown in the figure.

The courtesy lamp can be enabled or disabled by means of a GOL4 radio remote control and by storing the CH3 function (see instructions).

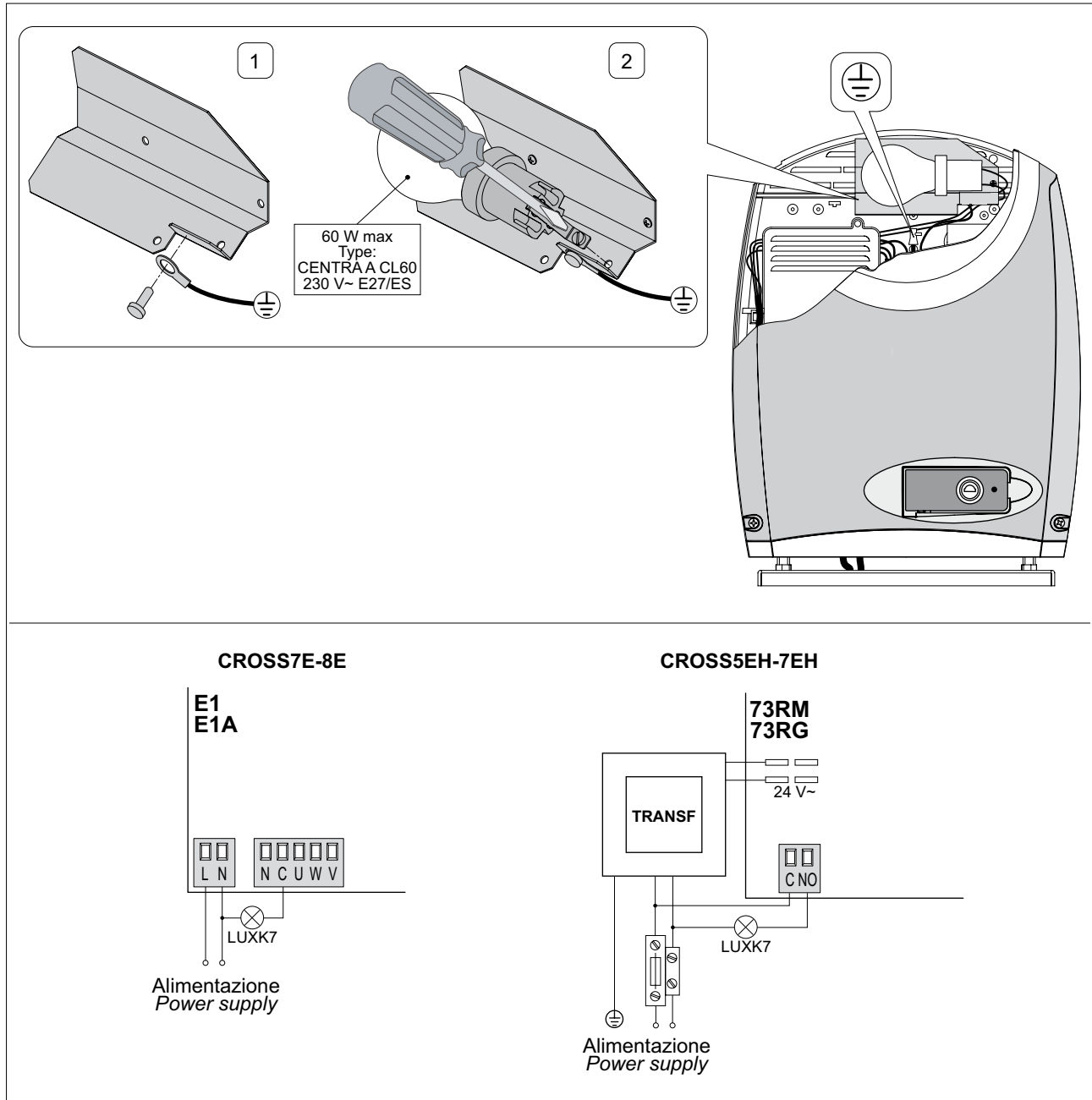

9. BATK7 INSTALLATION (only CROSS5EH-7EH)

The BATK7 battery kit permits to operate the gate even in case of mains power failure.

NOTE: when not in use, batteries are kept charged by means of the control circuit.

Fit the batteries inside the geared motor and secure by means of the appropriate support brackets (see BATK7 instruction manual).

10. ROUTINE MAINTENANCE PLAN

Perform the following operations and checks every 6 months according to intensity of use of the automation.

Disconnect the power supply and release the gearmotor (see RELEASE/BLOCK operations):

- Visually check that the gate, the fixing brackets and existing structure have suitable mechanical strength and are in good condition.
- Check the gate-gearmotor alignment, the distance (2-3 mm) between the throat of the pinion, the crest of the rack.
- Clean the wheel's sliding guide, the rack and pinion of the gear motor and slightly lubricate the rack and pinion of the gearmotor. Manually check that the gate slides evenly and without friction.
- Check the capacity value of the condenser.

Connect the power supply and block the gearmotor (see RELEASE/BLOCK operations):

- Check that the limit switches are working correctly (the gate should stop 20 mm before the stop).
- Check the power adjustment.
- Check that all control and safety functions are working correctly.



WARNING: For spare parts, see the spares price list.



11. OPERATING INSTRUCTIONS

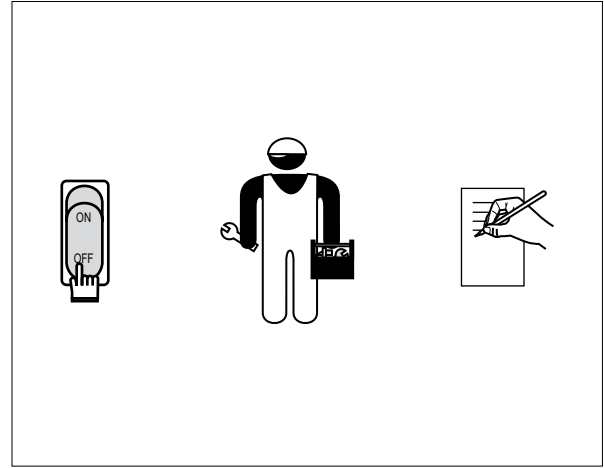
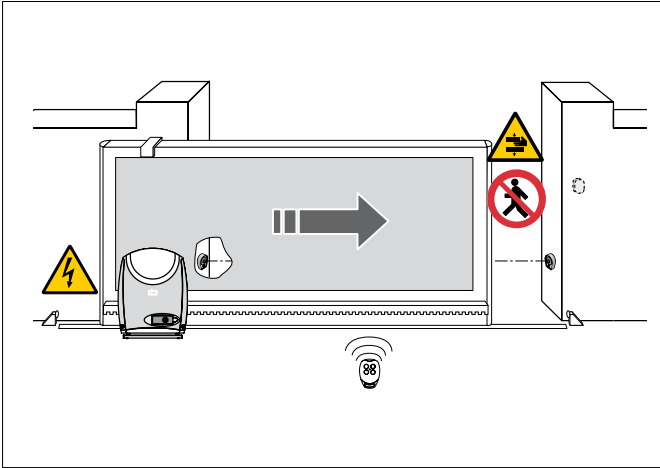

11.1 General safety precautions

The following precautions are an integral and essential part of the product and must be supplied to the user. Read them carefully since they contain important information on safe installation, use and maintenance. These instructions must be kept and forwarded to all possible future users of the system.

This product must only be used for the specific purpose for which it was designed.

Any other use is to be considered improper and therefore dangerous.

The manufacturer cannot be held responsible for any damage caused by improper, incorrect or unreasonable use.

Avoid operating in the proximity of the hinges or moving mechanical parts.

Do not enter within the operating range of the motorized door while it is moving.

Do not block the movement of the motorized door since this may be dangerous.

Do not allow children to play or stay within the operating range of the motorized door.

Keep remote controls and/or any other control devices out of the reach of children in order to avoid possible involuntary activation of the motorized door.

In the event of fault or malfunctioning of the product, turn off the power supply switch, do not attempt to repair or intervene directly and contact only professionally competent personnel.

Failure to comply with the above may cause a dangerous situation.

All cleaning, maintenance or repair work must be carried out by professionally competent personnel.

To ensure that the system works efficiently and correctly, the manufacturer's indications must be complied with and routine maintenance of the motorized door must be performed by professionally competent personnel.

In particular, regular checks are recommended in order to verify that the safety devices are operating correctly.

All installation, maintenance and repair work must be documented and made available to the user.

 For the correct disposal of electric and electronic equipment, waste batteries and accumulators, the user must take such products to the designated municipal collection facilities.



11.2 Manual release instructions

In the event of a fault or power failure, insert the key and turn it anticlockwise and completely open the door. Open the gate manually.

To block the gate again, close the door, turn the key clockwise and remove the key.



WARNING: carry out the wings blocking and release with the motor off.

When the door is closed, but the key is still horizontal, the release micro remains open and all gate operations are prevented.

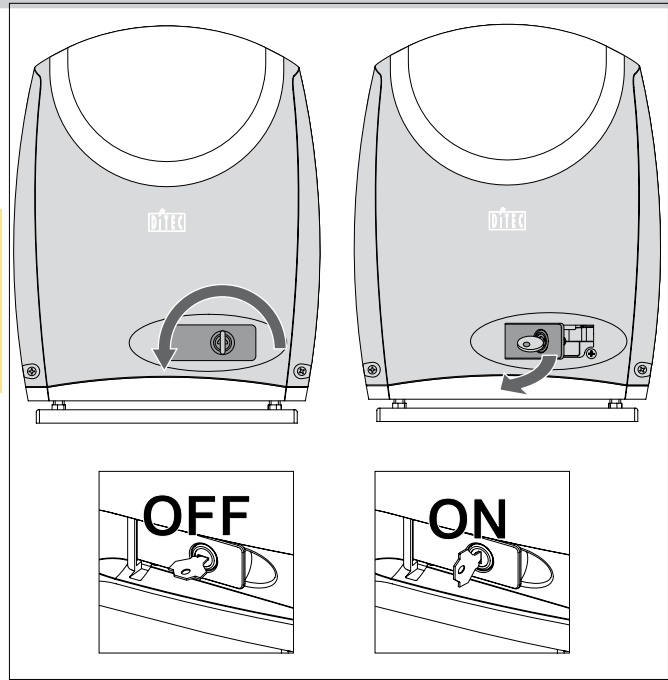

DITEC S.p.A.
Via Mons. Banfi, 3
21042 Caronno Pertusella (VA) - ITALY
Tel. +39 02 963911 - Fax +39 02 9650314
www.ditec.it - ditec@ditecva.com

Installer:



DITEC S.p.A. Via Mons. Banfi, 3 21042 Caronno P.Ia (VA) Italy Tel. +39 02 963911 Fax +39 02 9650314
www.ditec.it ditec@ditecva.com

DITEC BELGIUM LOKEREN Tel. +32 9 3560051 Fax +32 9 3560052 www.ditecbelgium.be **DITEC DEUTSCHLAND** OBERURSEL
Tel. +49 6171 914150 Fax +49 6171 9141555 www.ditec-germany.de **DITEC ESPAÑA** ARENYS DE MAR Tel. +34 937958399
Fax +34 937959026 www.ditecespana.com **DITEC FRANCE** MASSY Tel. +33 1 64532860 Fax +33 1 64532861 www.ditecfrance.com
DITEC GOLD PORTA ERMESINDE-PORTUGAL Tel. +351 22 9773520 Fax +351 22 9773528/38 www.goldporta.com **DITEC SVIZZERA**
BALERNA Tel. +41 848 558855 Fax +41 91 6466127 www.ditecswiss.ch **DITEC ENTREMATIC NORDIC** LANDSKRONA-SWEDEN
Tel. +46 418 514 50 Fax +46 418 511 63 www.ditecentrematicnordic.com **DITEC TURCHIA** ISTANBUL Tel. +90 21 28757850
Fax +90 21 28757798 www.ditec.com.tr **DITEC AMERICA** ORLANDO-FLORIDA-USA Tel. +1 407 8880699 Fax +1 407 8882237
www.ditecamerica.com **DITEC CHINA** SHANGHAI Tel. +86 21 62363861/2 Fax +86 21 62363863 www.ditec.cn